

INFRAMUNDO

Descenso / ascensión

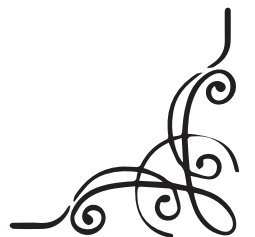

Joaquín Orellana

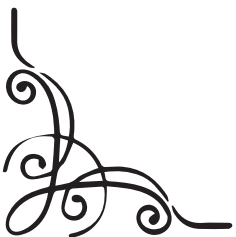

INFRAMUNDO
Descenso / ascensión

Joaquín Orellana

Obra realizada para:

Coro	Gran Cirlum
Sopranos	Estribel
Altos	Herroín
	Imbaluna
Cuerdas	Impomperia
8 Cellos	Lenguatón
6 Contrabajos	Multifonalia
	Multitún
Percusión	Periomín
Bass Drum	Pinzafer
Timpani	Pre-Ar
Plato suspendido	Prehimulinhos
	Pre-L
Útiles sonoros	Rebotrún
Burbuxá	Sonarimbas
CF-A	Tarros
CF-B	Teclambor
CF-C	Tejimar
Circumar	Termidia
Cirlum	Tubarc
	Ululantes I
	Ululantes II

Esta obra fue finalizada el 3 de julio de 2021

La presente obra se terminó de digitalizar el 20 de julio de 2021
por Francisco José Bustamante

Inframundo

Descenso / ascensión

Joaquín Orellana

(3 de julio de 2021)

frotados con barra de
madera estriada

$\text{♩} = 60$

Fermata sólo la vez

Estribel 1

Estribel 2

Herroín

Pinzafer

Cellos

mf

mf

Estribel 1

Estribel 2

Herroín

Pinzafer

Cellos

mf

Inframundo

10

B. Dr.

Cellos

14 **Piu mosso** ♩ = 75

G. Cirium

Herroín

Pinzafer

Teclambor

B. Dr.

Cellos

baqueta blanda de marimba

fp

Inframundo

3

20

B. Dr.

20

pp

Cellos

p

D. B.s

frotado con barra estriada
Tejimar + Herroin

frotado con barra estriada
Tejimar + Herroin

28

B. Dr.

28

f

Piu mosso ♩ = 80

mf

piatti sosp.

Cellos

f

frotado con barra estriada
Tejimar + Herroin

f

mf

D. B.s

f

mf pizz.

34

B. Dr.

34

B. Dr.

p

Cellos

D. B.s

39

B. Dr.

39

p

Calando

f

rit.

Cellos

D. B.s

Inframundo

Meno mosso $\text{♩} = 50$ *rit.* $\text{♩} = 75$

44

Cellos

D. B.s

6

Inframundo

*Los cellos y los contrabajos deben ser tocados apretando la cuerda con un frasco, y se percute con una barra de madera forrada de plástico. Las alturas y ritmos son aleatorios.

The score is divided into two systems. The first system includes:

- CF-A**: Violin I part with a box labeled '55' and an *accel.* marking.
- CF-B**: Violin II part.
- CF-C**: Viola part with an *accel.* marking.
- Circumar**: A circular percussion instrument.
- Herroín**: A woodwind instrument.
- Pinzafer**: A woodwind instrument.
- Resolam Multifonalia**: A multi-voice vocal part with staves labeled A, M, and G. It includes a *falsete modulado* section and a *cuerdas de piano* section.
- Tarros**: A percussion instrument.

The second system includes:

- Cellos**: A group of seven cello staves, each with a *gliss.* marking.
- D. B.s**: A group of three double bass staves.

Rehearsal marks and performance instructions include:

- 1o gliss.**: First ending with a glissando.
- 2o**: Second ending with lyrics: *dao uv e i a shiaiv* and *u av*.
- 30***: A final ending marked with an asterisk.

Inframundo

58

CF-A

CF-B

CF-C

Circumar

Herroín

Multitún

Pinzafer

Resolam Multifonalia

A
M
G

r r uv diuov

cuerda de piano
frotado

frotado

simil ad libitum

gliss. gliss.

gliss. gliss.

69 Heroin

Pinzafer

PreAr

69 Timp.

69 B. Dr. *frotado con cepillo* **f**

69 Cellos

hablado en murmullo

f *dimin.* ahsaliv tróem tróem irubash

f *dimin.* ushiv shalaish duladáim

f *dimin.* duldáim ladáim ulaish

D. B.s

The score is divided into two main sections. The upper section features a series of percussion instruments: Burbuxá, Circumar, Herroin, Imbalunas, PreAr, Prehimulinhos, Sonarimbás, Termidia, and Utulantes I. Each instrument has a unique icon and specific rhythmic notation. The lower section features a Double Bass (D. B.s) section with six staves, each playing a different Hebrew phrase. The lyrics are: *ahsaliv tróem tróem*, *ushiv duladáim*, *daim shalaish*, *daladáim ushiv*, *tróem ashaliv*, and *shalasih ushiv tróem*. The score includes dynamic markings such as *f* (forte) and *p cresc.* (piano crescendo), and performance instructions like *densif.* (dense) and *>* (accent). A rehearsal mark **71** is present at the beginning of several staves.

Inframundo

Lento

Allegro ♩ = 100

73

CF-B

CF-C

Circumar

Cirlum

Herroín

Imbalunas

Lenguatón

Pinzafer

Prehimulinhos

Resolam Multifonalia

Termidia

Ululantes I

Ululantes II

73

Timp.

73

un chelo no divisi
idem los demás

idem cada uno de los
otros 7

gliss. lento

f

gliss. lento

f

gliss. lento

f

Inframundo

13

78 **Lento** $\frac{4}{4}$

CF-B $\frac{4}{4}$

CF-C $\frac{4}{4}$

Cirlum $\frac{4}{4}$

Herroín $\frac{4}{4}$

Pinzafer $\frac{4}{4}$

Resolam Multifonalia $\frac{4}{4}$

78 $\frac{4}{4}$

Timp. $\frac{4}{4}$

78 $\frac{4}{4}$

B. Dr. $\frac{4}{4}$

78 $\frac{4}{4}$

Cellos $\frac{4}{4}$

gliss.
gliss. lento

$\frac{4}{4}$

gliss lento $\frac{4}{4}$

D. B.s $\frac{4}{4}$

81 $\text{♩} = 65$

Estribel 1

Pinzafer

Soprano

Timp.

B. Dr.

Cellos

D. Br.s

i

divisi

pizz.

Inframundo

15

85

Burbuxá

G. Cirlum

Pre-L

S

Alto

85

Timp.

85

B. Dr.

85

Cellos

D. B.s

pizz.

pizz.

pizz.

gliss.

i

i

i

The musical score is arranged in a vertical stack of staves. At the top, three percussion staves are labeled 'Burbuxá', 'G. Cirlum', and 'Pre-L', each with a box containing the number '85'. Below these are the vocal staves for Soprano ('S') and Alto. The Alto staff includes the instruction 'gliss.' and a fermata. The percussion section continues with 'Timp.' (Timpani) and 'B. Dr.' (Bass Drum), both with '85' in a box. The string section consists of three staves for 'Cellos' and three for 'D. B.s' (Double Basses), with 'pizz.' (pizzicato) markings. The score is divided into measures by vertical bar lines, with a change in time signature from 3/4 to 4/4 occurring in the second measure of each staff.

The score is divided into several systems. The first system includes five percussion parts: Cirium (drum), Impomperia (woodblock), Periomín (triangle), Pre-L (gong), and Tubarc (cymbal). The Cirium part starts with a circled '90' and a drum icon. The Impomperia part features a woodblock icon and a zigzag line. The Periomín part has a triangle icon and a dotted pattern. The Pre-L part has a gong icon and teardrop shapes. The Tubarc part has a cymbal icon and horizontal lines. The second system features a vocal line (S) with a treble clef and a note marked 'i'. The third system includes Timp. (Tympani) and B. Dr. (Bass Drum) parts, both starting with a circled '90'. The fourth system is for Cellos (Violins), with four staves in treble clef, each starting with a circled '90'. The fifth system is for D. B.s (Double Basses), with three staves in bass clef.

Transcripción por Francisco José Bustamante

Iconografía de Útiles Sonoros

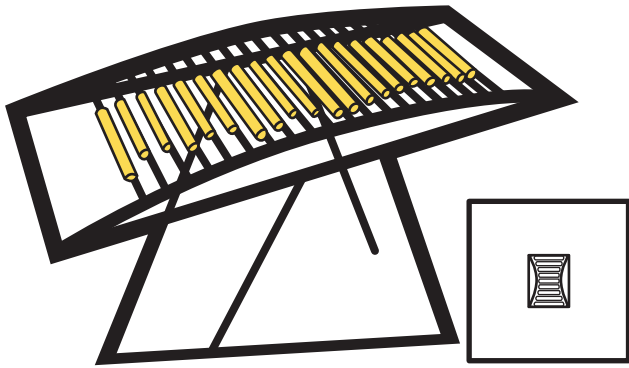

Burbuxá

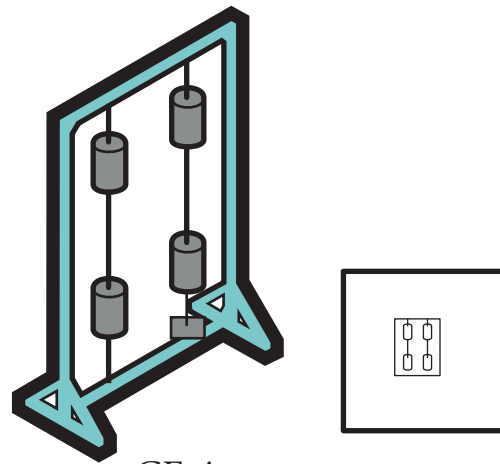

CF-A

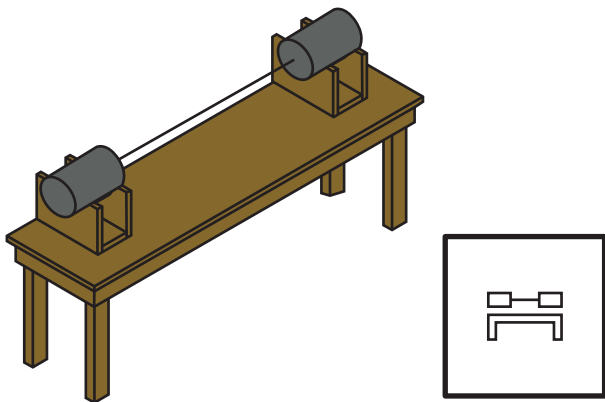

CF-B

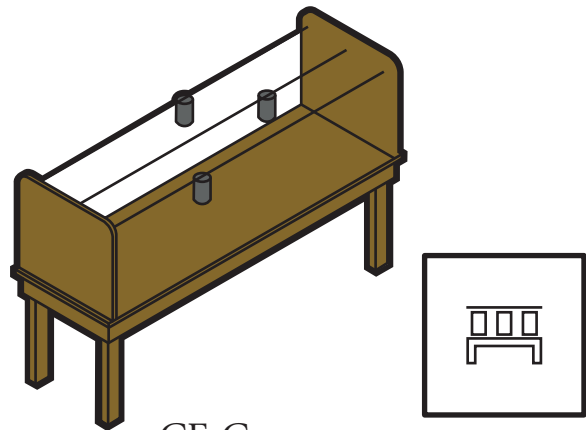

CF-C

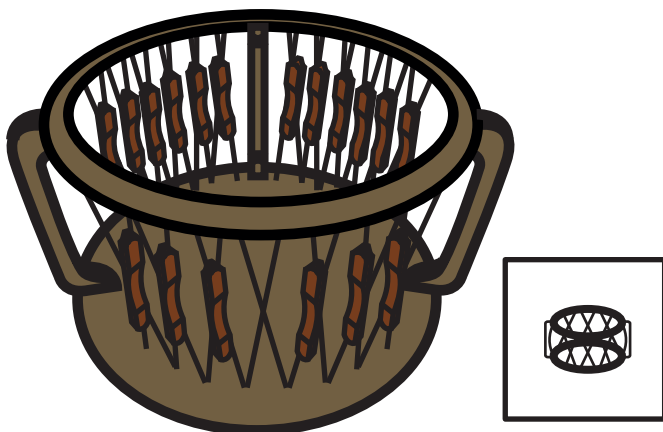

Circumar

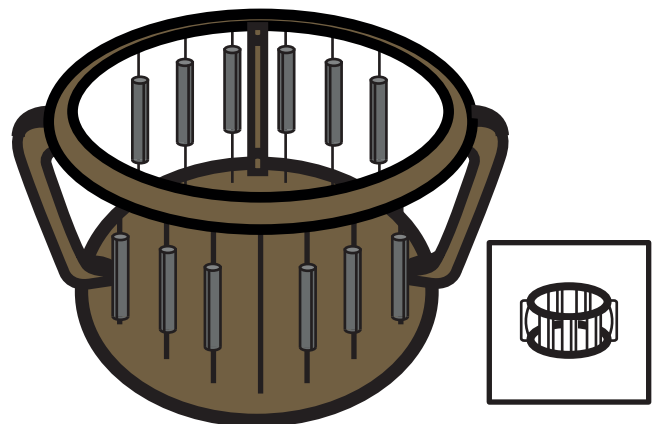

Cirlum



Herroín

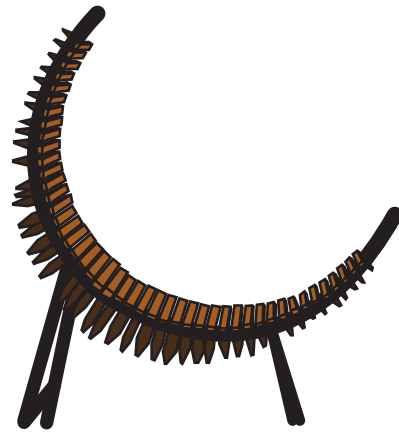

Imbaluna

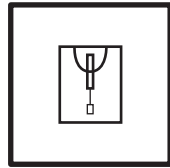
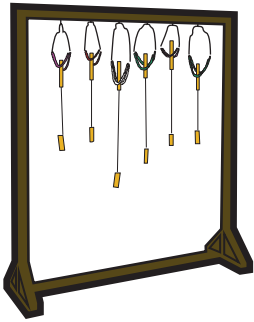

Impomperia

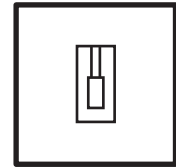
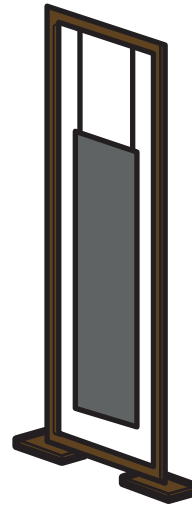

Lenguatón

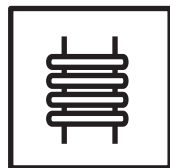
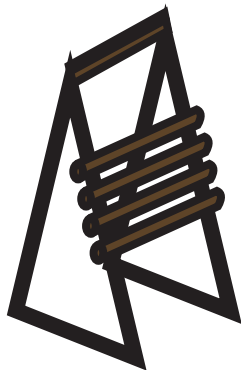

Multitún

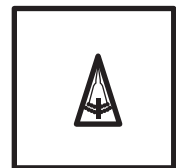
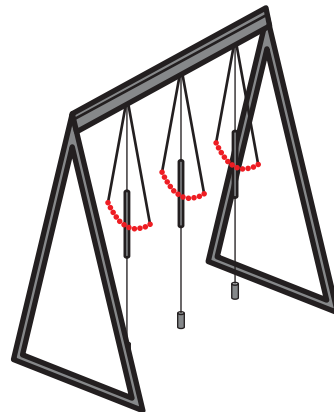

Periomín

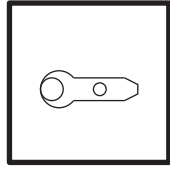

Pinzafer

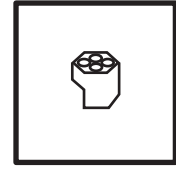

Pre-Ar

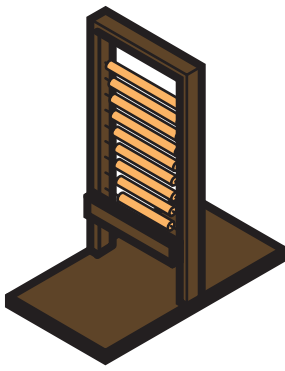

Prehimulinhos

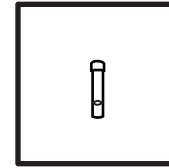

Pre-L

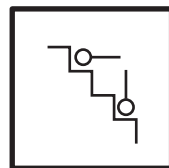
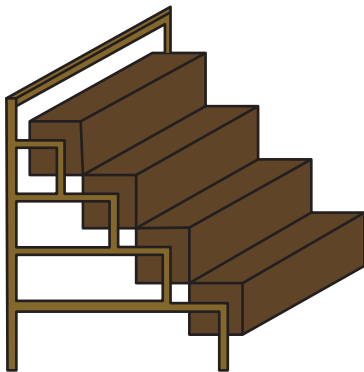

Rebotrún

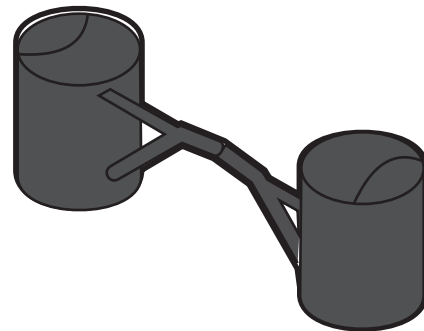

Multifonalia

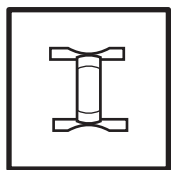
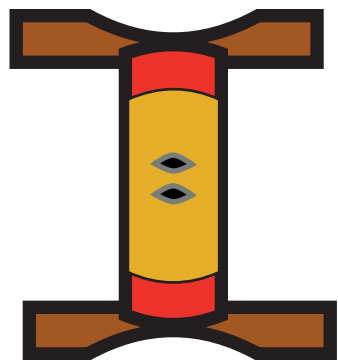

Sonarimba

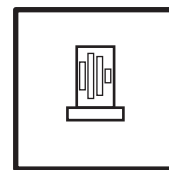
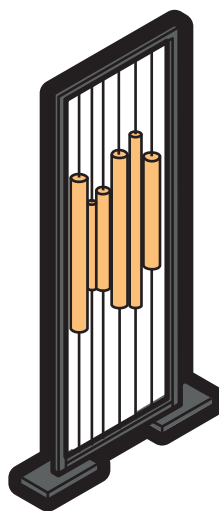

Tarros

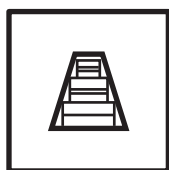
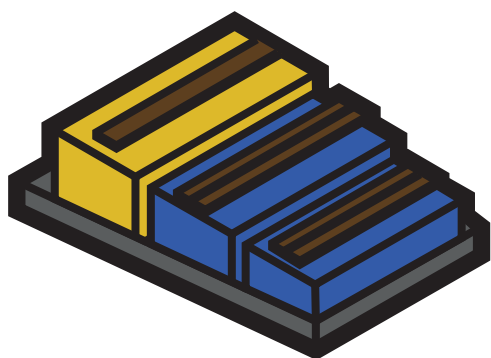

Teclambor

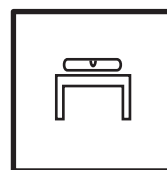
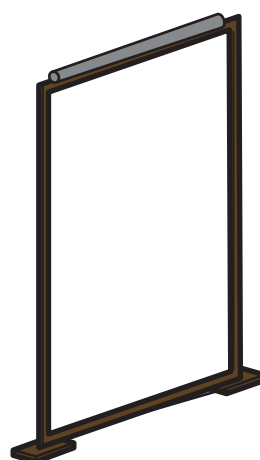

Tubarc

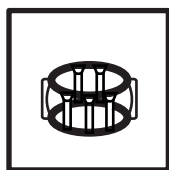
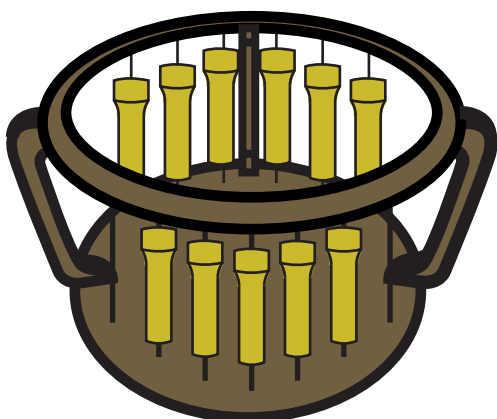

Ululantes I

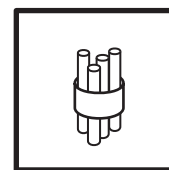
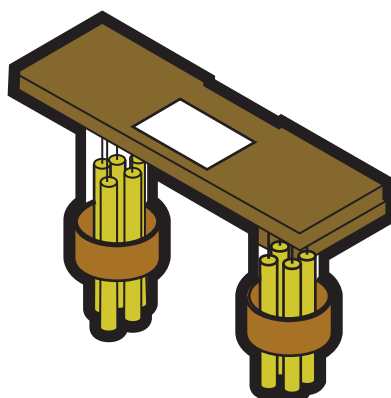

Ululantes II

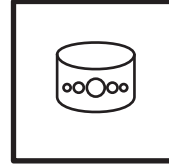
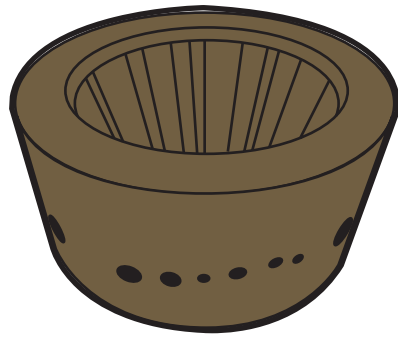

Termidia